

FlexMod

FLEXIBLE MODULAR ANALYSIS SYSTEM

KEY FEATURES

- Flexible and Modular Surface Analysis System Design
- Optimized Analysis Modules for Spectroscopy, Microscopy and Sample Preparation
- Multi-Method System Capabilities
- Easy and Cost Effective Upgrade Options



SPeCS™

SPECS leads the way in state-of-the-art technology for surface analysis.

SPECS Surface Nano Analysis GmbH

SPECS has more than 130 employees at its headquarters in Berlin and its subsidiaries in Switzerland, the USA and China. The company also has liaison offices in Spain and BeNeLux, supported by international sales channels in sixteen countries. A team of scientists and engineers is involved in developing and producing scientific instruments for surface analysis, materials science and nanotechnology.

Packaging of a SPECS
component after final
testing

Final alignment of an UHV
high precision sample
manipulator



Since the company was founded in 1983, its success is based on a continuous gain in experience. SPECS scientists are in close contact with a large number of customers and scientists around the world. SPECS is your essential partner in scientific instrumentation due to our focus on customer support, know-how and international contacts. Scientists all over the world can rely on SPECS product quality and be inspired by the continuous development of new products.

FlexMod

FLEXIBLE MODULAR ANALYSIS SYSTEM

Content

FlexMod Concept	4
FlexPS – System Module for Electron Spectroscopy	6
FlexPM – System Module for Scanning Probe Microscopy	10
FlexPrep – System Module for Sample Preparation	14
FlexIntro – System Module for Sample Introduction	16
FlexAdd – Flexible Add-on Modules	18
FlexMan – Flexible Sample Manipulation	20
FlexVac – Flexible Pumping System	24
FlexBake – Flexible Bake Out Concept	26
FlexMod Configurations	27

FlexMod Concept

FLEXIBLE MODULAR ANALYSIS SYSTEM

Surface Nano Analysis tools combining uncompromised performance with an upgradeable, cost-effective system concept

Standard system solutions and stand-alone systems in most cases only can answer standard questions. The integration of several analytical techniques requires a more sophisticated approach. Such integration can include sample preparation, thin film deposition, surface analysis in ultrahigh vacuum, and even methods working in other environments or *in situ* analysis under working conditions. Thus, advanced applications in surface analysis and surface nano analysis require a significant degree of customization regarding the analysis system design.

The dilemma here is, that customized solutions take a long time to be realized, and are significantly more expensive. Furthermore, normally they are not flexible to later changes, because geometries and specifications are only optimized for the defined purpose. Later upgrades, if possible at all, will lead to a system concept with a high degree of complexity in operation.

The way out of this maze would be a modular concept, well known to many of us from childhood days. Transfer the pleasure of playing with building blocks to modern research. Concentrate on solving scientific problems, instead of diving into the small details of complicated system designs. Start from well-planned, well-specified and application-optimized building block type modules for a dedicated task. With all modules having equal form factors, immediate or later combination of several of these optimized modules help to build-up a multi-method system, exactly optimized to the recent application and in future even growing with extended tasks.

The future of customization is available: SPECS FlexMod.



The FlexMod system concept provides the scientist with an optimized, but still customizable solution, for a variety of surface science techniques. The system allows you to start with a basic configuration and expand with upgrade options towards improved performance or expansion to more additional methods. This means the system can grow with you and your needs.

The individual modules are optimized in functionality for the chosen method. Within the module it is possible to select from a large number of components for analysis. In addition, we offer

several choices for pumping configuration and sample manipulation which allow you to adapt the system to your needs. Individual modules can be operated as stand-alone systems or be combined from multi-method system configurations.

The system configuration can also be rearranged to adapt to new experimental requirements. Accompanied by comprehensive automation, FlexMod is the perfect solution for multi-user environments as well. Convince yourself of this concept and start to adapt the surface nano analysis system to your research, instead of limiting your research by the equipment available in your lab.

FlexPS

SYSTEM MODULE FOR ELECTRON SPECTROSCOPY

The specially designed UHV chamber provides an optimized geometry for all electron spectroscopy applications. It allows a combination of XPS, UPS, AES and ISS methods with full performance for each method.

The heart of the FlexPS UHV system module is the specially designed analysis chamber. It is optimized to fulfill the geometrical requirements for all common electron- and ion spectroscopy applications. The chamber is made of μ -metal in order to optimize magnetic shielding and allow the highest energy resolution. For less sensitive applications, a stainless steel chamber is also available. The system base can be equipped with a variety of pumping configurations to

meet specified gas load and base pressure requirements. Thanks to the unique design, components can easily be added, upgraded and exchanged. Within the flexible system concept, different sample handling options can be chosen with respect to sample size, temperature range and manipulation possibilities. The FlexMod PS allows sample sizes up to 2" using manipulation possibilities with up to 6 degrees of freedom. It offers fitting solutions for all standard heating

FlexPS System – Standard UHV System Module with optional components for electron spectroscopy



and cooling operations, thus covering a broad temperature range. Additional sample storage slots can be implemented to increase the system's efficiency or to upgrade for multi-user operation.

Configuration Options for Electron Spectroscopy

Centerpiece for electron spectroscopy is the hemispherical analyzer PHOIBOS. It is a highly flexible electron analyzer with available configurations for ESCA, XPS, ARXPS, ARPES, UPS, AES, SAM, ISS, snap shot data acquisition and 2D detection modes. Special detectors with extended dynamic range offer high count rates while the special analyzer design results in the best energy resolution down to 2 meV in UPS and lateral resolution to below 50 μm in XPS.

Depending on the application, suitable excitation sources can be chosen from a wide range of options:

- X-ray sources for XPS/ESCA including twin anode X-ray source XR 50 and monochromatic X-ray source FOCUS 500 and the small spot μ -FOCUS monochromator sources
- Electron source EQ 22 for AES and electron sources for SEM/SAM down to 100 nm lateral resolution
- UV sources for UPS: UVS 10/35, UVS 300 and UVLS with optional monochromator or polarizer
- Flood Gun FG 15/40 for charge compensation
- Ion sources for sample preparation, depth profiling and ISS: IQE 11/35, IQE 12/38 or gas cluster ion sources
- Sample manipulator with up to 6 axis, sample size up to 2" and heating and cooling facilities

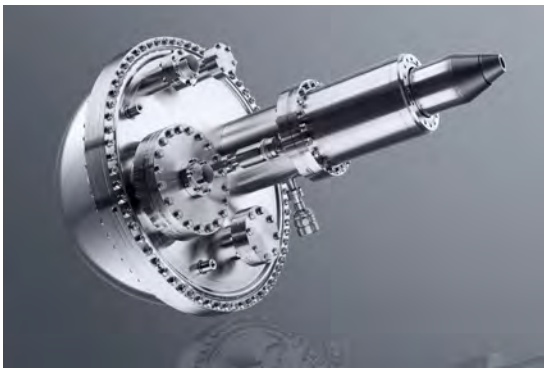

Hemispherical Analyzer
PHOIBOS



Twin Anode X-Ray Source
XR 50



Monochromatic X-Ray
source FOCUS 500

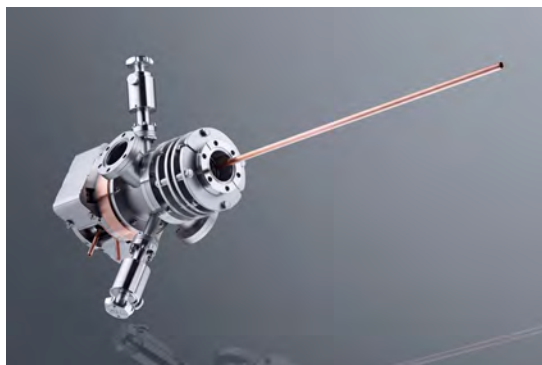

High Performance UV
source UVS 300

Applications

ESCA/XPS/ARXPS

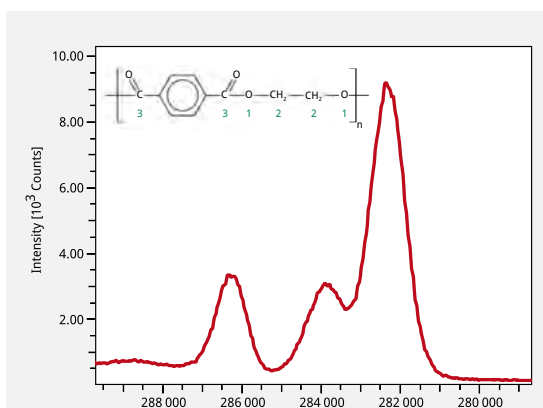

The high resolution capability of the PHOIBOS analyzer combined with the FOCUS 500 monochromator and the flood gun FG 15/40 has been demonstrated by XPS measurements on a PET (polyethylene terephthalate) surface. In the analysis of polymeric surfaces, monochromatic sources offer a significant advantage over non-monochromatic sources due to the improved resolution. This allows to distinguish even small energy shifts which are caused by different bonding. When using monochromatic X-rays however, spectra can be difficult to obtain due to surface charging effects when analyzing non conducting organic materials. In order to record high quality data under these circumstances, it is necessary to neutralize surface charging carefully. The FG 15/40 is a compact, easy to handle, reliable flood gun for charge neutralization. The C1s spectrum above shows the ability to distinguish carbon atoms 1, 2 and 3 with a FWHM of 0.8 eV.

UPS/ARPES

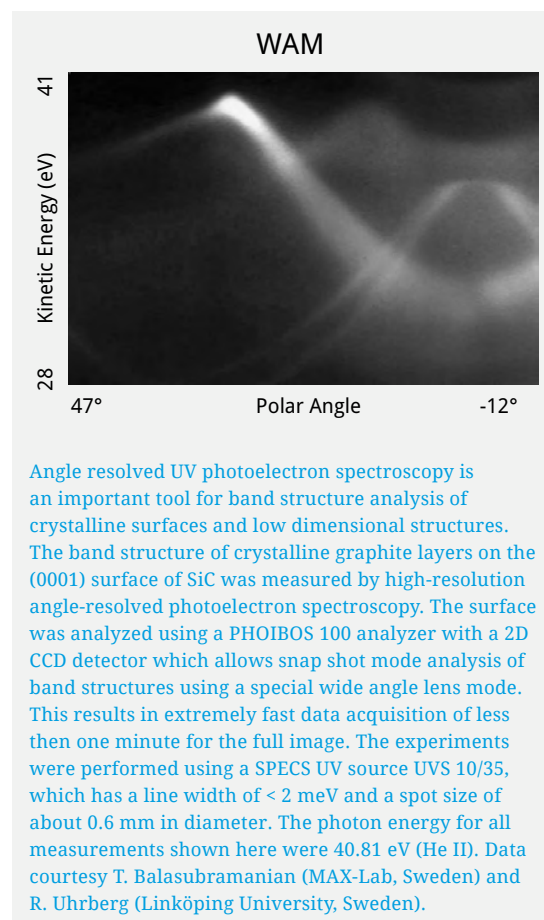

Angle resolved UV photoelectron spectroscopy is an important tool for band structure analysis of crystalline surfaces and low dimensional structures. The band structure of crystalline graphite layers on the (0001) surface of SiC was measured by high-resolution angle-resolved photoelectron spectroscopy. The surface was analyzed using a PHOIBOS 100 analyzer with a 2D CCD detector which allows snap shot mode analysis of band structures using a special wide angle lens mode. This results in extremely fast data acquisition of less than one minute for the full image. The experiments were performed using a SPECS UV source UVS 10/35, which has a line width of < 2 meV and a spot size of about 0.6 mm in diameter. The photon energy for all measurements shown here were 40.81 eV (He II). Data courtesy T. Balasubramanian (MAX-Lab, Sweden) and R. Uhrberg (Linköping University, Sweden).

AES/SEM/SAM

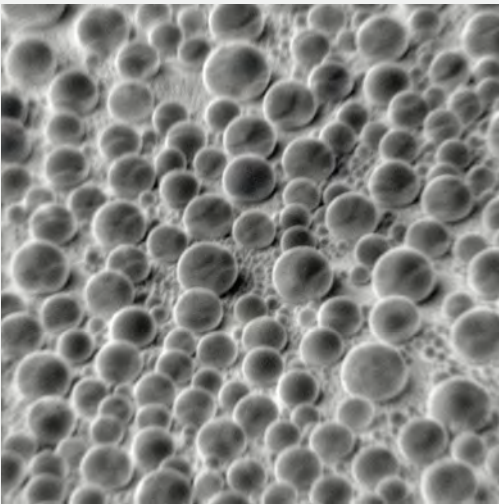

Secondary Electron Microscopy (SEM) images of Sn balls on graphite.
Size 5 nm -30 μm

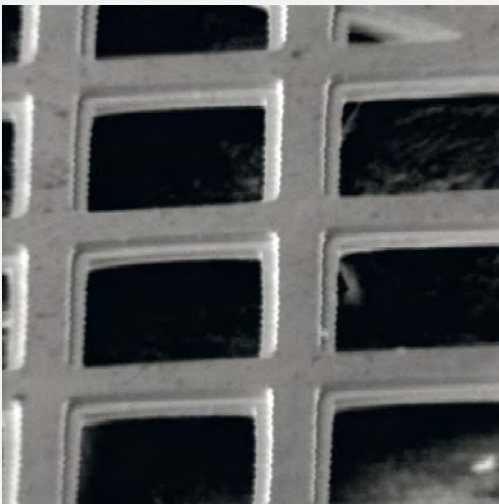

Secondary Electron Microscopy (SEM) image of copper square mesh G300.
300 lines/inch, 25 μm bar width, 58 μm hole width

Depth Profiling and ISS/LEIS

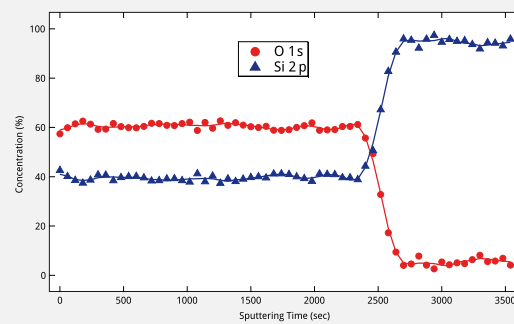

Depth profiling of 100nm SiO₂ layer on Si (standard sample for depth calibration) based on XPS signal during ion sputtering. Shown is the atomic concentration for silicon and oxygen elements calculated from the XPS intensity of the Si 2p and the O 1s element lines. The interface between the SiO₂ layer and the Si wafer substrate is visible as a sharp edge with a width of 7 nm (20 % to 80 %).

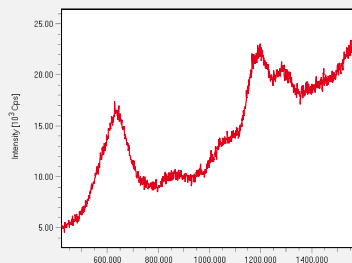
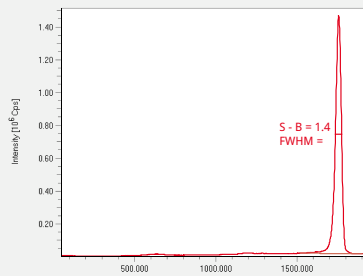

Ion Scattering Spectroscopy (ISS) measurement of He ion scattering on Ag surface with analyzer PHOIBOS. The ISS method is extremely surface sensitive and can give important additional information to the electron spectroscopic methods.

FlexPM

SYSTEM MODULE FOR SCANNING PROBE MICROSCOPY

SPECS engineers have developed a dedicated chamber module design for atomically resolved STM and AFM in UHV or under Near Ambient Pressure (NAP) conditions.

The FlexPM system module integrates a variety of in situ sample preparation techniques with outstanding atomically resolved SPM performance in one dedicated chamber design. Due to the special SPECS SPM 150 Aarhus design, the configuration is very small and flexible. The extreme stability of the SPM 150 Aarhus allows a variety of different pumping configurations, including the option of using turbo pumps for

high gas loads. Even in noisy surroundings, atomic resolution is achieved without external vibrational damping. The system includes ports for *in situ* tip and sample preparation with ion sources and evaporators. A sample storage can be added for convenient sample loading while viewports are included as standard configuration for easy sample handling.

FlexPM System – Standard UHV system module with optional components for Scanning Probe Microscopy

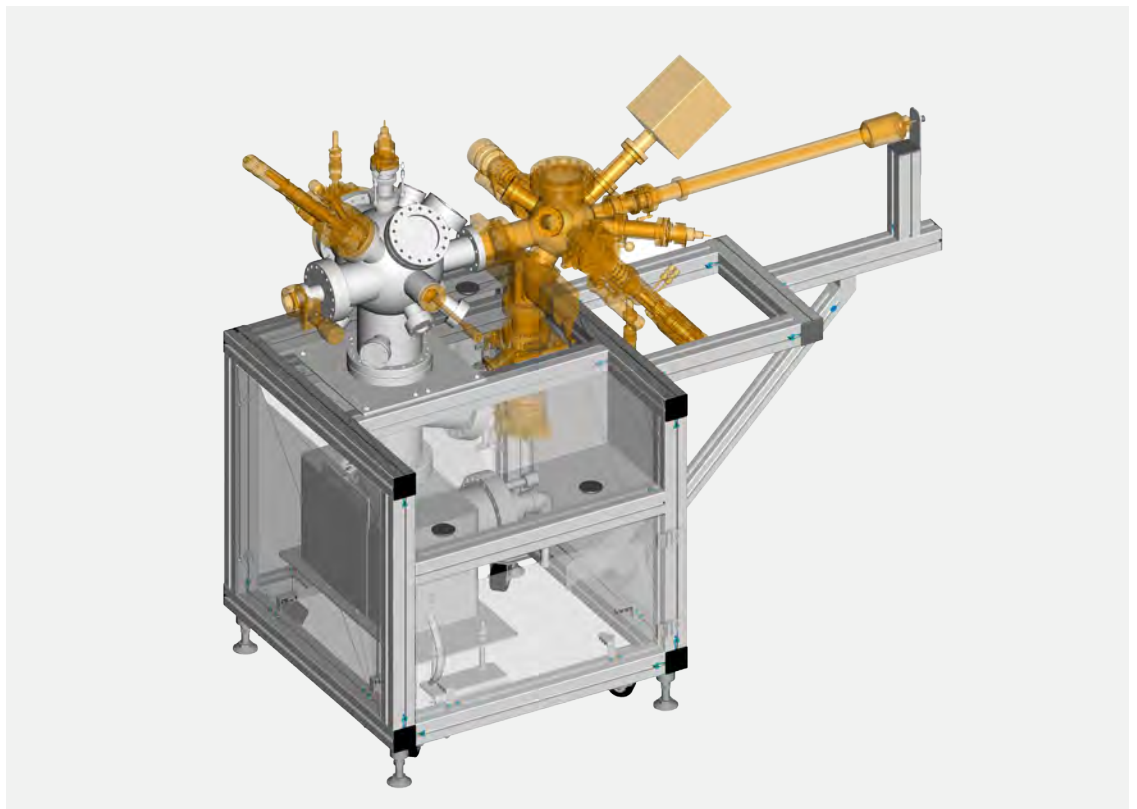

Configuration Options for Scanning Probe Microscopy

The Scanning Probe Microscopy Module is based around the high stability SPM 150 Aarhus Series. The Series includes configurations for pure STM and for STM/AFM combinations. For AFM, the special KolibriSensor is used which has a unique cross talk free parallel performance for STM and AFM. In all configurations, *in situ* tip preparation for optimum resolution in SPM is a unique feature of the Aarhus design. Fastest STM electronics as well as high flexibility Nanonis electronics for SPM can be chosen. The temperature range for SPM can be chosen from liquid nitrogen or helium to high temperatures up to 1300 K.

Depending on the application, suitable accessories for sample preparation can be chosen from a large range of options:

- Ion source IQE 11/35 for sample preparation and tip preparation
- E-beam evaporators in single pocket, EBE-1, or multi pocket, EBE-4, configuration for thin film deposition
- Sample storage with heating stage for sample preparation through direct current heating up to 1400 K



KolibriSensor for parallel STM and AFM data acquisition with highest stability

UHV Scanning Probe Microscopy Head SPM Aarhus 150

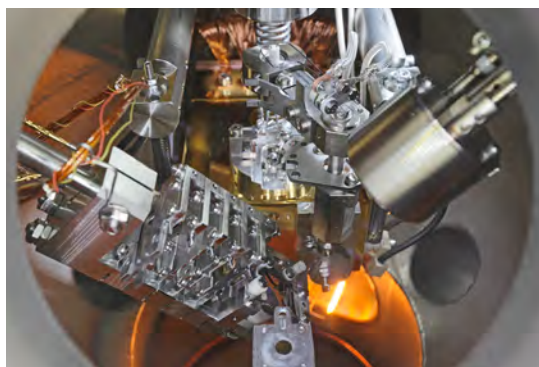

Ion Source for *in situ* tip preparation

Sample storage and heating stage for sample preparation

STM Applications

Defect mobility on O(2x1)-Ru(0001)

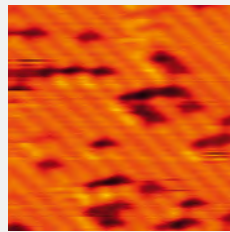
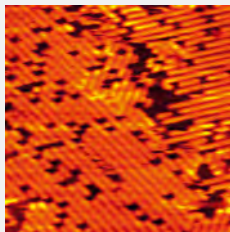
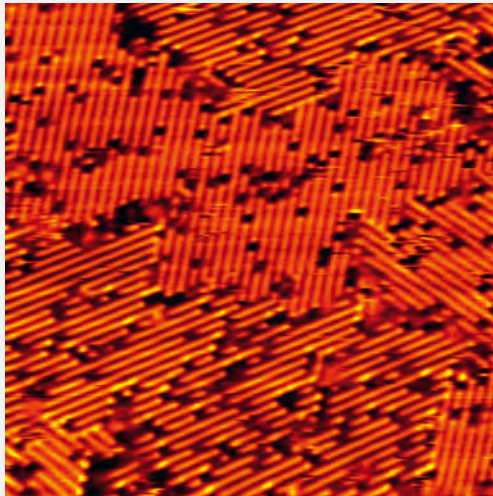

Instrument: SPM 150 Aarhus with KolibriSensor
Imaging parameters:
Constant current STM images $I = 0.57$ nA, $U = 1.473$ V
Image size:
20 nm x 20 nm, 12 nm x 12 nm, 4 nm x 4 nm
Temperature: room temperature
Images taken at SPECS laboratory
The O(2x1)-Ru(0001) surface consists of different domains rotated by 120° with respect to each other.
At room temperature mobility of point defects imaged as dark spots on top of the bright rows is observed.

Graphene on Ru(0001) imaged at 700°C with atomic-resolution

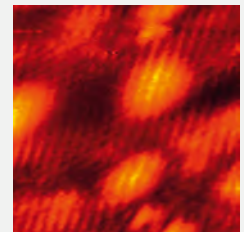
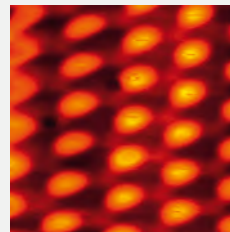
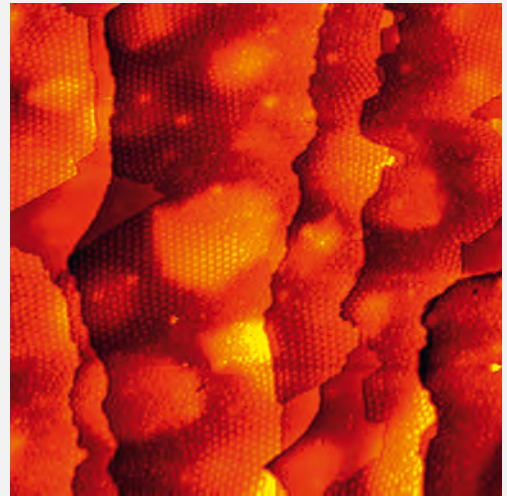

Instrument: SPM 150 Aarhus HT with W-STM tip
Imaging parameters:
Constant current STM images $I = 0.37$ nA, $U = 0.013$ V
Image size:
150 nm x 150 nm, 12 nm x 12 nm, 4 nm x 4 nm
Temperature: 700°C
Images taken at SPECS laboratory
The graphene was grown by chemical vapor deposition of ethylene on the hot Ru(0001) sample inside the microscope. The sample was heated by radiation from a hot filament to 700°C throughout preparation and imaging.

AFM Applications

Graphene on Ru(0001)

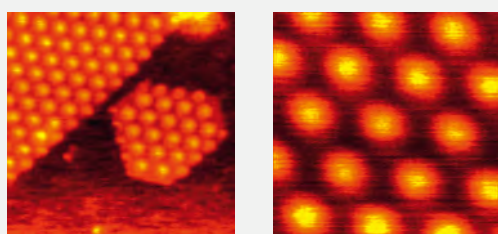
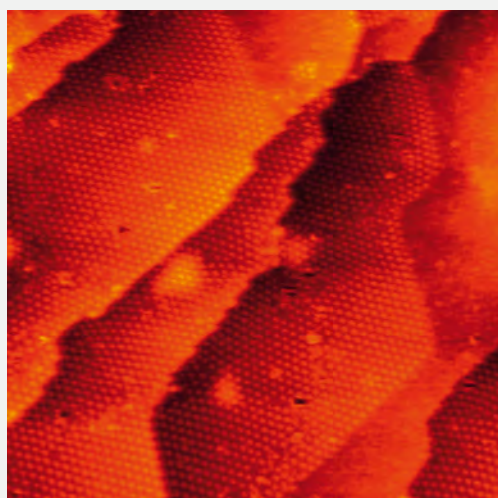

Graphene on Ru(0001)

Instrument: SPM 150 Aarhus with KolibriSensor

Imaging parameters:

Constant detuning NC-AFM image

Df = -0.08 Hz, U = -0.16 V, fres = 999,154 Hz, A = 300 pm,

Q = 29600

Image size: 150 nm x 150 nm, 30 nm x 30 nm,

9 nm x 9 nm

Temperature: room temperature

Images taken at SPECS laboratory

The graphene was grown by chemical vapor deposition of ethylene on Ru(0001). At low coverages the growth of monolayers and isolated islands was observed.

Water layer on KBr(001)

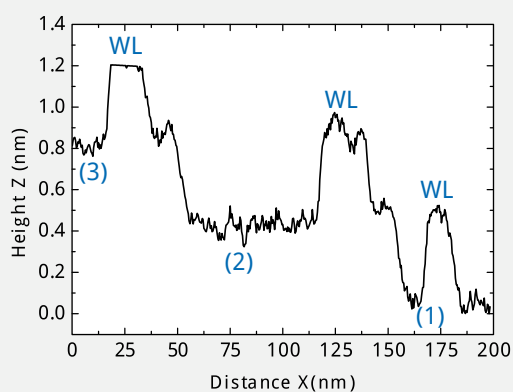
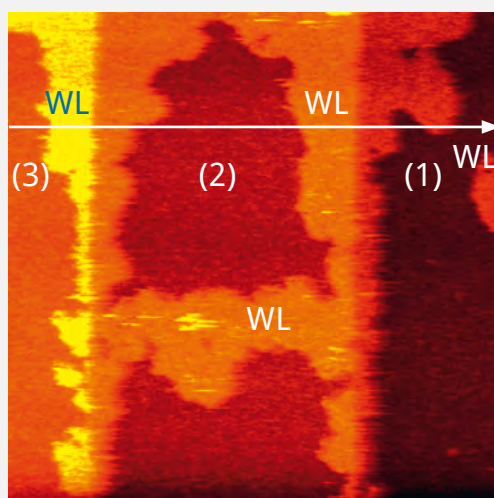

Instrument: SPM 150 Aarhus with KolibriSensor

Imaging parameters: Constant detuning NC-AFM image

Df = -0.3 Hz, fres = 996,581 Hz, Q = 3500, A = 500 pm

Image size: 200 nm x 200 nm Temperature: 130 K

Image taken at SPECS laboratory

At low temperatures the formation of a water wetting layer is observed on the KBr(001) surface. The wetting layer nucleates preferentially at step edges

FlexPrep

SYSTEM MODULE FOR SAMPLE PREPARATION

For in situ sample preparation SPECS offers an optimized and versatile chamber module solution.

The FlexPrep module is designed to integrate a variety of *in situ* preparation techniques including ion etching, e-beam deposition, as well as LEED and RHEED analysis. SPECS also provides the corresponding components and accessories. The FlexPrep module is an extension of the FlexPS and FlexPM modules for separate but *in situ* sample preparation. This allows the highest purity level in analysis combined with the required flexibility for preparation.

The pumping configuration can be selected to meet gas load and base pressure requirements. Within the flexible system concept, sample handling offers standard choices regarding sample size, temperature range and manipulation possibility, to meet the optimum experimental requirements. It includes solutions up to 2" sample size with up to 5 degrees of freedom and extended sample heating and cooling features. In addition, sample storage facilities can be added.

FlexPrep System –
Standard UHV System
Module with optional
components for sample
preparation

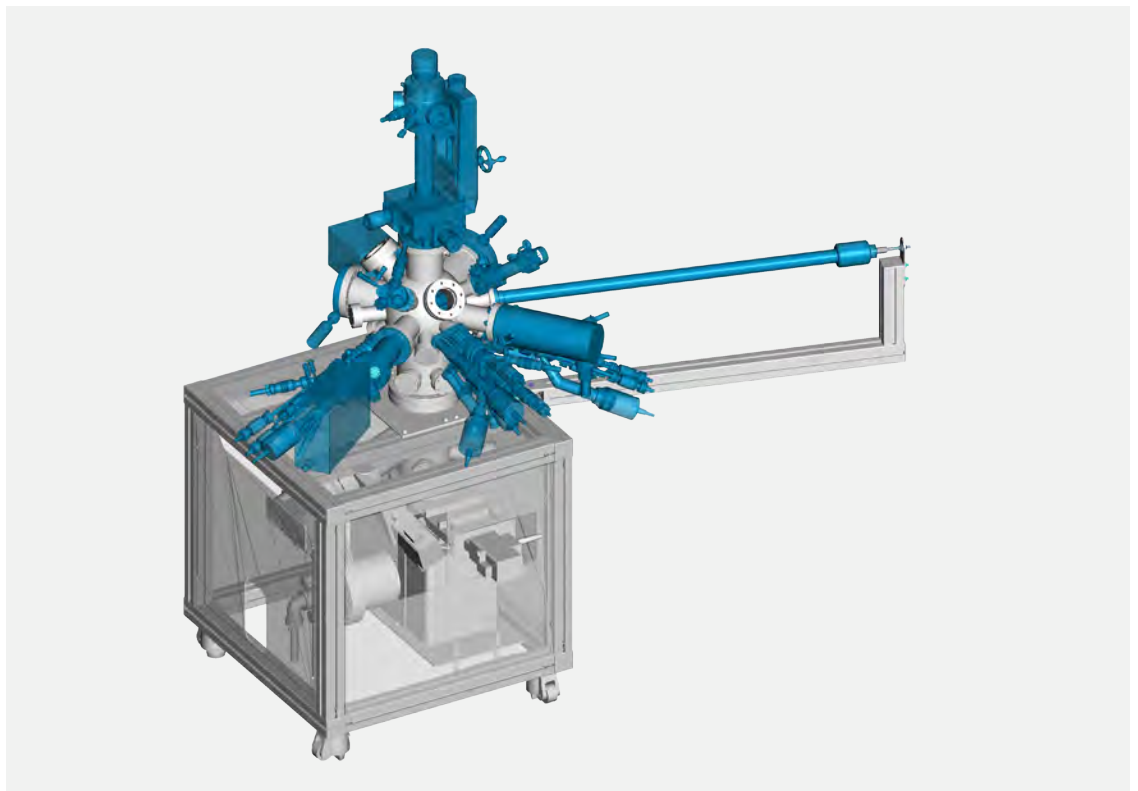

Configuration Options for Sample Preparation

Depending on the application, suitable accessories for sample preparation can be chosen from a wide range of options:

- Ion source IQE 11/35 for sample cleaning
- Plasma sources PCS-ECR, MPS-ECR or PCS-RF for sample preparation with reactive gases, e.g.
 - Nitriding (GaN, AlN, InN and SiN), doping (ZnSe), alloying (GaInNAs, GaAlAsN)
 - Oxygen: HTC superconductors, optical coatings, dielectrics, reactive sputtering, laser ablation and ceramic growth (Al_2O_3)
 - Oxygen cleaning and oxidation kinetics, post growth oxidation /low temperature SiO_2
 - Hydrogen: Cleaning, growth enhancement / surfactant
 - Chlorine: In-situ etching methane (carbon): SiC film growth
- E-beam evaporators in single pocket, EBE-1, or multipocket, EBE-4, configurations for thin film deposition
- LEED optics ErLEED with Auger option and Safire software package for image acquisition and evaluation
- RHEED RHD-30 package with Safire software option and elevated pressure option
- Sample manipulator with up to 6 axis, sample size up to 2" and heating and cooling possibilities



LEED Optics ErLEED 150



Plasma source PCS ECR for sample preparation



RHEED package RHD 30 for *in situ* analysis

E-Beam Evaporator EBE-4

FlexIntro

SYSTEM MODULE FOR SAMPLE INTRODUCTION

Load lock systems with fast access sample loading door for easy and fast sample loading without system venting. The systems have minimized volumes for fast pumping down.

Load Lock Module FlexIntro

Special fast sample introduction module with minimized volume for fast pump down. Pumping options include an independent turbo pump station or a cost efficient bypass solution. The system is designed for sample handling and loading of the SPECS SH2/12 sample plates for sample sizes up to 10 mm x 10 mm

Load Lock Module FlexIntro Plus

Advanced multipurpose module system with upgrade paths for sample preparation and rotary sample distribution. The system has extended sample handling capabilities for up to 2" sample sizes, sample storage possibilities and rotary sample distribution. Optimized ports for sample preparation options, like heating for degassing, ion sputtering and deposition are included. The

Sample Introduction
Systems for FlexMod
System Moduls: FlexIntro
and FlexIntro Plus

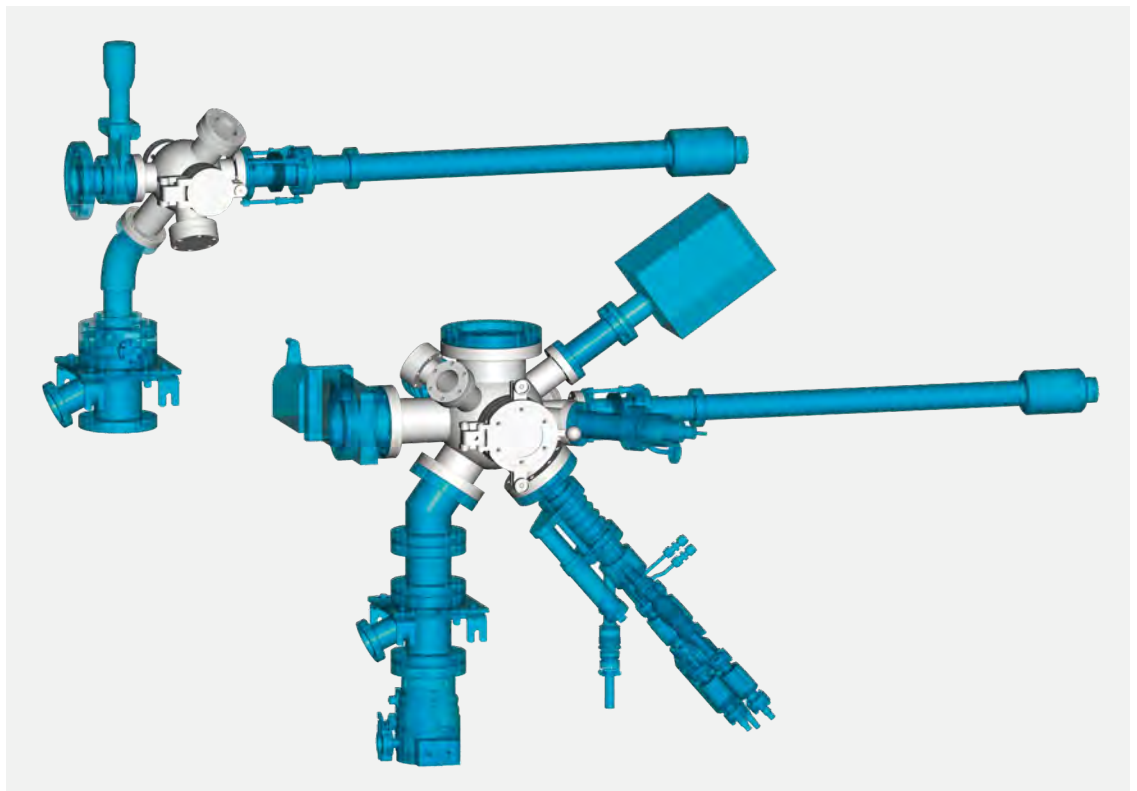

pumping configuration can be chosen to suit the desired base pressure, pump down speed and gas loads.

Configuration Options for FlexIntro

- Sample storage for up to 8 samples

Configuration Options for FlexIntro Plus

- Sample storage for up to 8 samples
- Radial sample distribution with sample carousel for up to 8 samples and connection of up to 5 satellite chambers
- Sample preparation: Ion Source IQE 11/35, Hydrogen Cracker Source TGC-H, e-beam evaporators, EBE-1 or EBE-4 or Plasma Sources



Rotary sample storage and distribution for 6 samples plates type SH 2/12 with z-retract



Linear sample storage for 6 SH 2/12 type samples plates, double sided for compact design

FlexAdd

FLEXIBLE ADD-ON MODULES

Compact and cost efficient bolt-on stations for FlexMod System Modules. SPECS systems can be upgraded with different compact add-on chambers.

FlexMod Add-On Options

The idea of FlexMod concept is maximum flexibility combined with dedicated solutions for surface science. FlexAdd modules allow extension of dedicated FlexMod systems in a compact and cost effective way. Existing frames and pumping systems can be used and the capability of the system extended by just adding an additional chamber for specific methods.

SPECS offers flexible customized add-on modules, for example for IRAS, ellipsometry, etc. as well as dedicated standard add-on modules for scanning probe microscopy, preparation and high pressure reaction experiments.

Standard FlexAdd Modules

FlexPM Bolt-On Module

SPM extension for standard FlexPS or FlexPrep System Modules. The main chamber pumping system can be used if an ion pump is fitted. Can be mounted to an existing frame.

FlexPrep Bolt-On Module

Preparation extension for standard FlexPS or FlexPM System Modules. Pumping system of main chamber can be used. Can be mounted to the existing frame.



FlexPrep Bolt-On Module added to FlexPS System Module with equipment options

High Pressure Cell FlexHPC 20

Special Bolt-On solution for SPECS System Modules for *in situ* analysis of catalytic reactions. Specialized design with minimized reaction volume and chamber in chamber design with water cooled inner chamber and special sealing mechanism for operation up to 20 bar. SPECS has implemented a special heating mechanism by halogen lamp which only heats the reactive

sample area and therefore prevents reactions at other surfaces and allows heating in reaction conditions up to 800°C. The high pressure cell works with a wide range of gases including O₂, CO₂, N₂, H₂, and all inert gases. The sample handling is designed for SPECS type SH 2/12 sample plates for up to 10 mm x 10 mm sample size.



FlexMan

FLEXIBLE SAMPLE MANIPULATION TYPE SH 2/12

Flexible configuration with up to 5 degrees of freedom for sample manipulation and selection of Z-travel, including heating, cooling and optional motorization.

Specifications

- x-, y- translations: +/- 12 mm
- precision: +/- 10 μ m

Z Translation:

- selectable for 4 axis manipulator: 200 mm, 300 mm, 500 mm, 700 mm, 900 mm
- selectable for 5 axis manipulator with azimuthal rotation: 200 mm, 300 mm, 500 mm
- selectable for 5 axis manipulator with continuous azimuthal rotation: 200 mm, 500 mm
- selectable for 5 axis manipulator with tilt: 500 mm
- precision: +/- 50 μ m
- polar rotation: +/-180°
- precision: +/- 0.1°

Selectable Second Rotation:

- azimuthal rotation (in plane): +/-90°
- continuous azimuthal rotation (without cooling option)
- out of plane sample tilt: +/-30°
- liquid nitrogen cooling possibility down to 90 K included for all configurations, besides the continuous rotation option.
- optional He cooling
- sample heating possibility with e-beam heating up to 800 °C continuous and up to 1200 °C flash heating, optional power supply with PID controller

5 axis UHV sample manipulator with full motorization and SH 2/12 sample stage with additional sample storage possibility

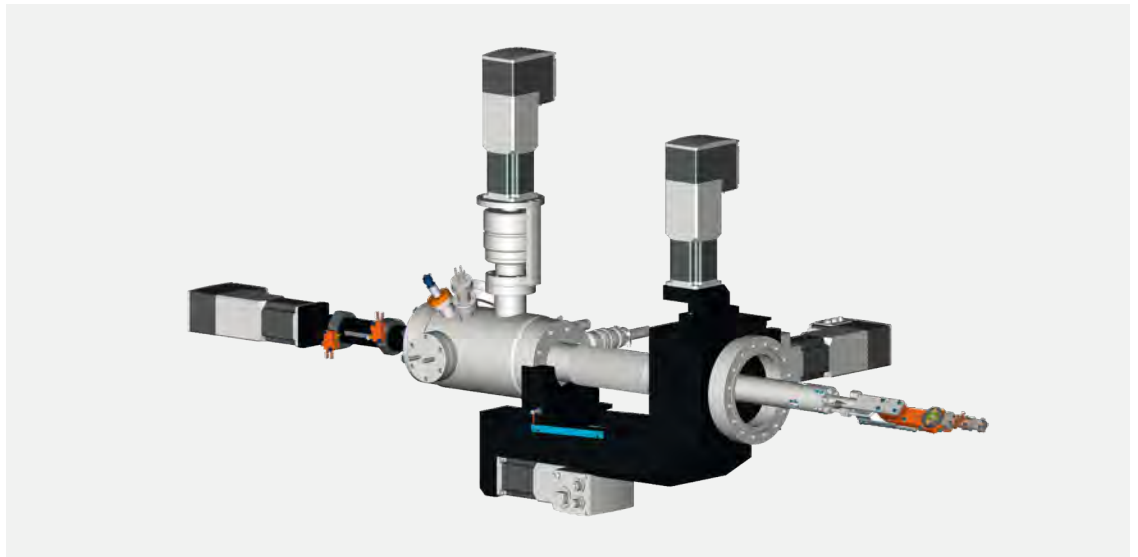

Sample Transfer

For sample mounting, a variety of transferable sample plates are available. Samples are mounted directly to the sample plates, offering flexible operation. Heating and cooling options are integrated in the manipulator stage. The sample plates are transferred with a special transfer tool with sample locking mechanism mounted to a magnetically coupled transfer rod.

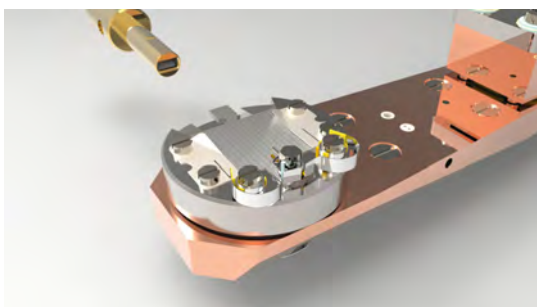
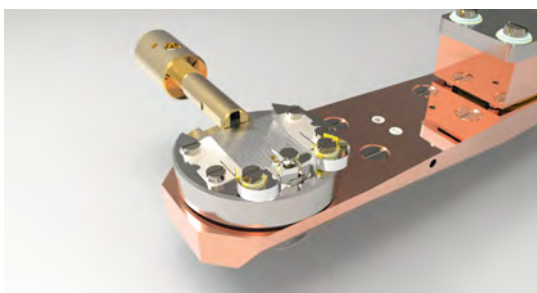
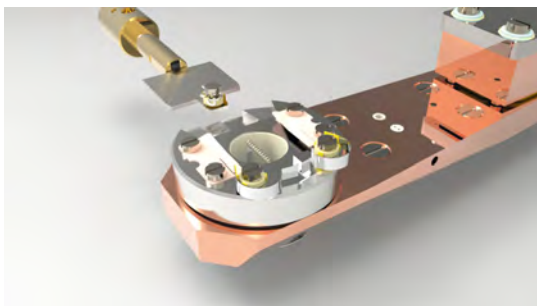

Transfer of sample plate with transferable thermocouple connections to heatable and coolable sample stage

SPECS Sample Holder type SH 2/12

- For mounting of samples with sizes up to 12 mm x 12 mm
- Minimum sample thickness of 0.5 mm, maximum thickness 4 mm,
- Optional sample holder for 1" sample plates
- Sample bias connection included
- Filament and connections for e-beam heating up to 800 °C continuous heating and up to 1200 °C short time heating included
- Liquid nitrogen cooling down to 90 K included for all models except the 5 axis continuous rotation version
- Thermocouple fixed to sample stage



Sample holder stage with SH 2/12 sample plate inside FlexPS module in front of electron spectroscopy equipment

Sample Manipulation Options

- Power supply EBH-150 with PID controller for temperature regulation including interface for PC control
- Transferable thermocouple connection for precise temperature measurement at the sample surface, for example for temperature programmed desorption studies
- Sample storage for up to three samples mounted to manipulator
- Motorization of individual manipulator axis or all axis and PC control possibility



Sample Plates for SPECS Sample Holder type SH 2/12

- Variety of different sample plates available for direct current heating, e-beam heating, powder samples, etc.
- Different materials available including stainless steel, Ta and Mo.

Standard stainless steel SH 2/12 sample plate with 4 threaded holes for sample mounting



Special SH 2/12 sample plate for direct current heating, e. g. for heating of semiconductors like Si up to 1400 °C



Special SH 2/12 high temperature sample plate for high temperature e-beam heating up to 1400 °C



Special SH 2/12 sample plate for "hat"-shaped crystals



Sample Holder Plate Dimensions

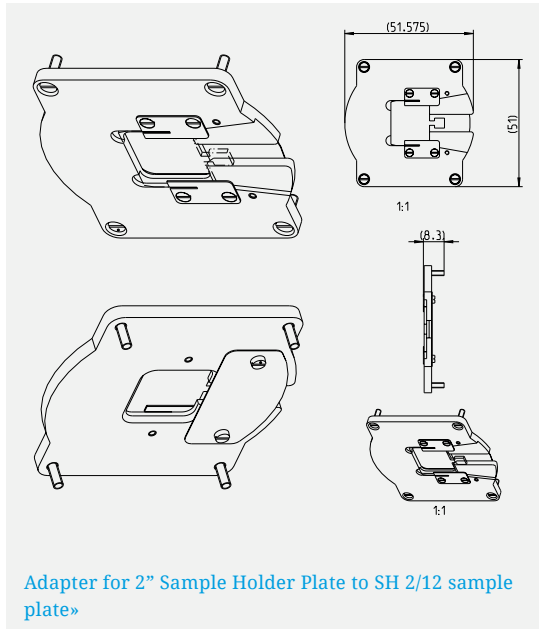
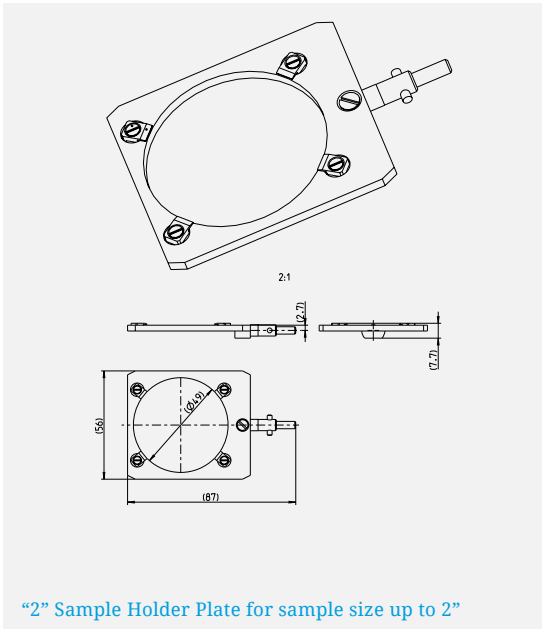
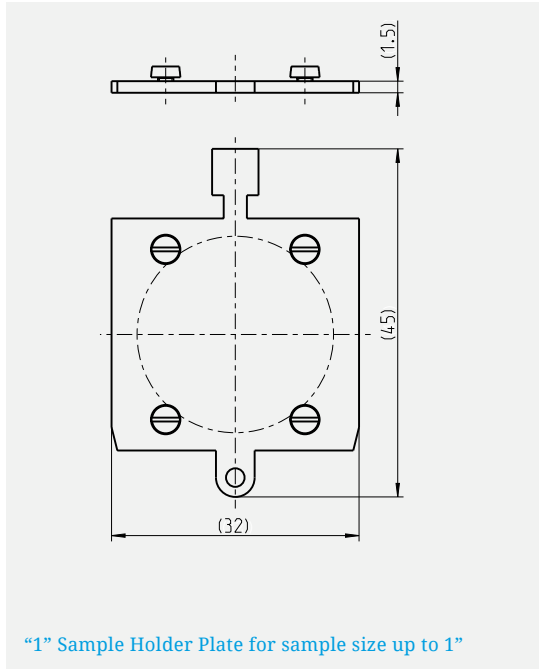
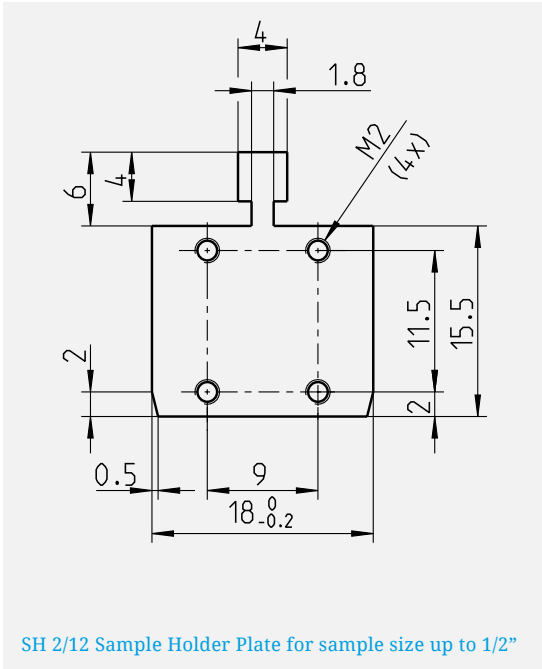

FlexVac

FLEXIBLE PUMPING SYSTEM

The FlexMod system frame is designed to allow for a variety of pumping configurations depending on your requirements.

The FlexMod concept offers high flexibility, and this also applies to the pumping system. It is possible to start with a basic pump configuration for UHV generation and upgrade to more advanced systems for higher gas load or lower pressures later. The frame and pumping ports are prepared to accommodate different configurations including different turbo pump sizes, ion getter pumps and titanium sublimation pumps. Generally, SPECS implements oil free pumps to achieve optimum vacuum conditions. Special oil free scroll pumps are used as roughing pumps.

FlexMod systems are also always equipped with the necessary pressure measurement packages consisting of Bayard-Alpert ion gauges, Penning cold cathode gauges and Pirani gauges depending on the vacuum range of the corresponding FlexMod module.

The system frame also allows upgrades for vibrational damping and attachment of additional frame modules.

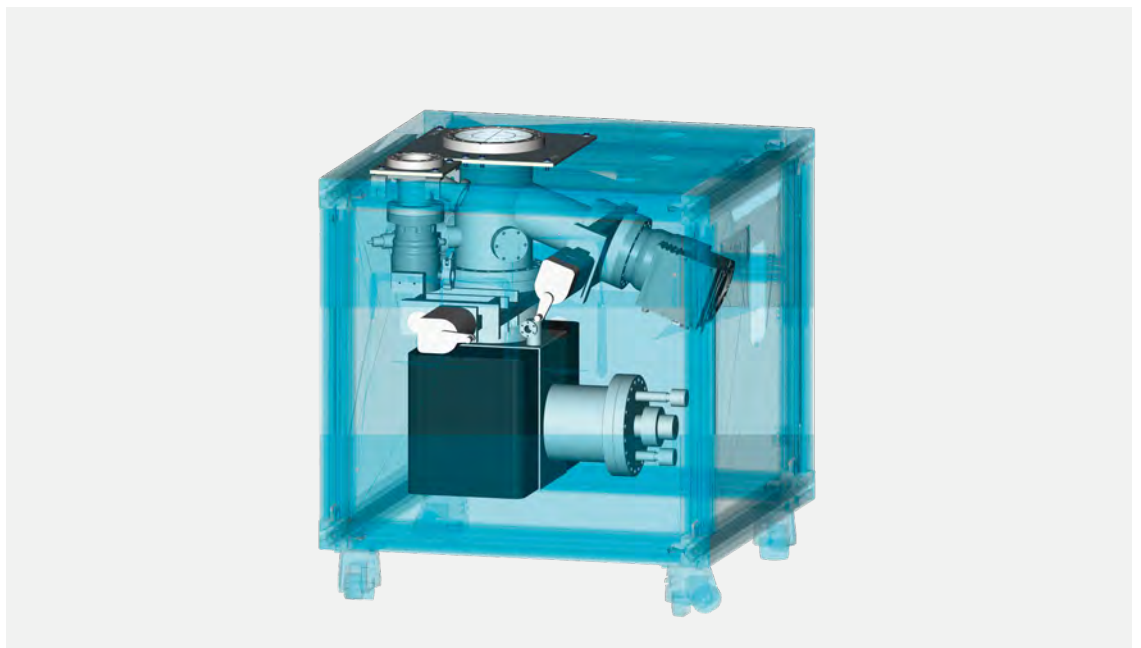

Pumping Configuration Options for FlexPS, FlexPM and FlexPrep

	Final Base Pressure	Pump configuration
Small	$< 9 \times 10^{-10}$ mbar	Turbo pump 260 l/s N ₂ , Titanium sublimation pump, scroll pump
Medium	$< 5 \times 10^{-10}$ mbar	Turbo pump 685 l/s N ₂ , Titanium sublimation pump, scroll pump
Large	$< 2 \times 10^{-10}$ mbar	Turbo pump 260 l/s N ₂ , Ion pump 240 l/s N ₂ , Titanium sublimation pump, scroll pump
Ion	$< 5 \times 10^{-10}$ mbar	Ion pump 240 l/s N ₂ , Titanium sublimation pump

Pumping Configurations for FlexIntro

	Final Base Pressure	Pump configuration
Small	9×10^{-8} mbar	Bypass to main system module (only with turbo pump as main chamber)
Medium	5×10^{-8} mbar	Turbo pump 71 l/s N ₂ , Scroll pump
Large	2×10^{-8} mbar	Turbo pump 260 l/s N ₂ , Scroll pump

Additional Options

- Gate valves, pneumatic or manual
- Pressure measurement with software control

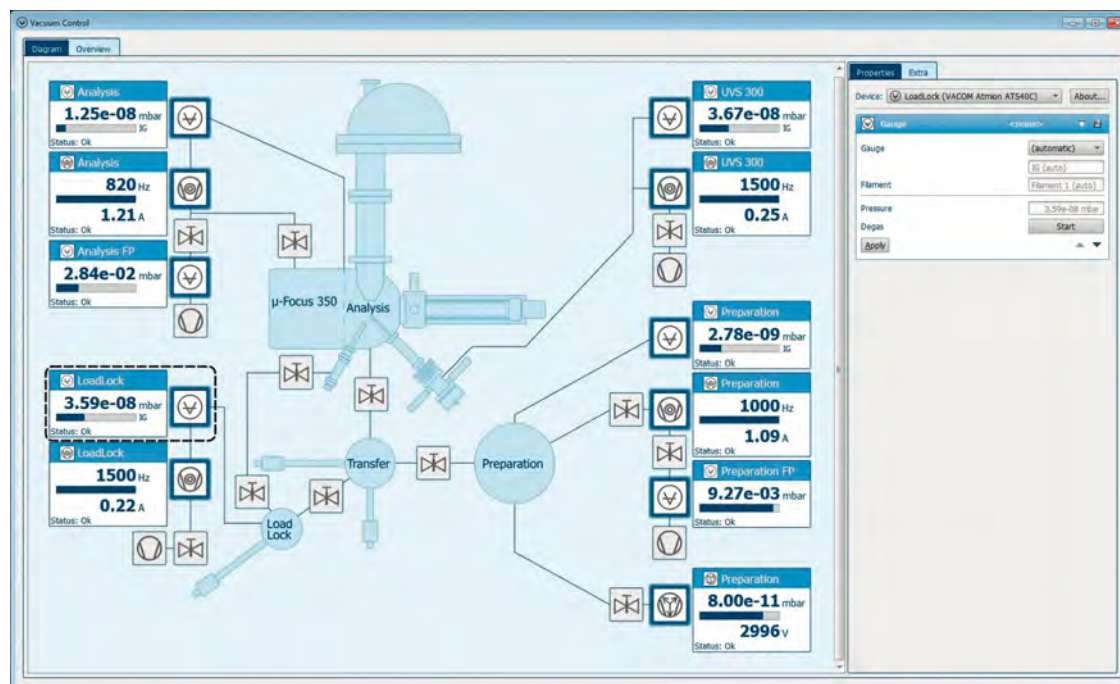

Pressure and pump control
by software package
SpecsLab Prodigy

FlexBake

FLEXIBLE BAKE OUT CONCEPT

To achieve optimum UHV conditions the FlexMod system module is equipped with a specially designed bakeout tent. The tent consists of a flexible and easy to handle cover and a rigid form.



To achieve purest vacuum conditions all FlexMod Modules are complemented by an easy to use bakeout system. It uses a well established oven like principle to ensure a homogeneous temperature distribution throughout the bake out process. The bakeout tent is made of a heat resistant insulation layer supported by rigid metal frame which includes the heating units and fans. Insulation layer and frame are composed of simple modular parts. This ensures compliance with the FlexMod concept as the bakeout tent can

easily grow with the system. Moreover it allows a convenient single user installation and reduces the necessary storage space to a minimum. For automated operation the control unit is equipped with a programmable temperature control and a timer function.

FlexMod Configurations

THE MODULAR CONCEPT

The FlexMod system concept allows a wide range of combinations, particularly reconfiguration and expansion schemes. Examples of the FlexMod System Concept are shown. Inspired by the examples? Please contact us for your specific configuration and design.

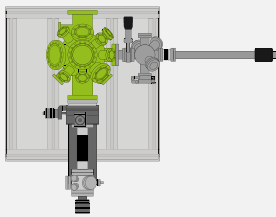

Electron Spectroscopy System consisting of FlexPS and FlexIntro Classic

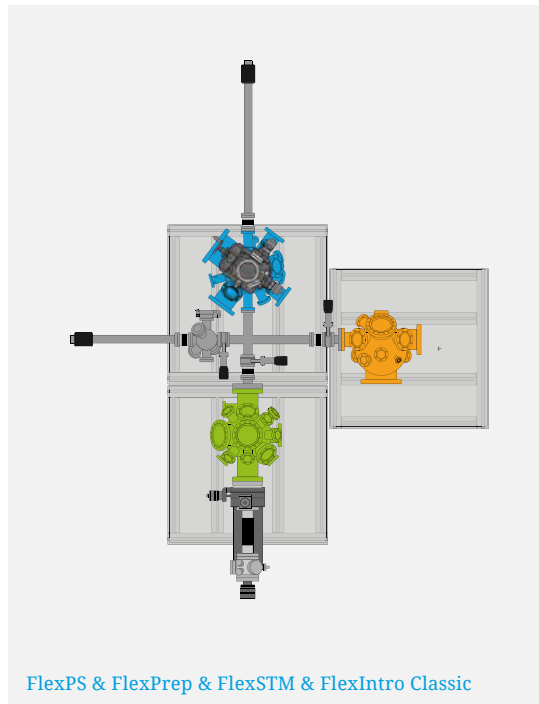

FlexPS & FlexPrep & FlexSTM & FlexIntro Classic

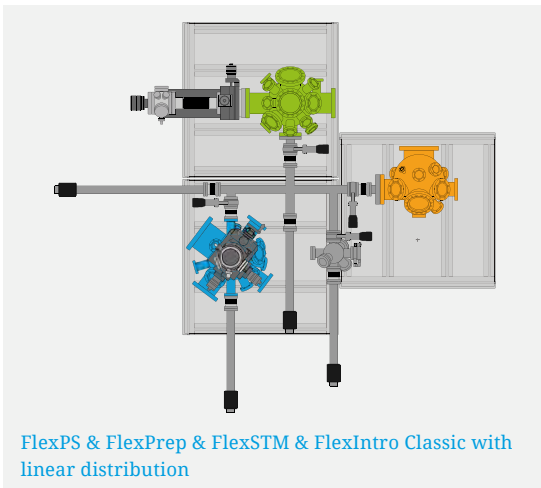

FlexPS & FlexPrep & FlexSTM & FlexIntro Classic with linear distribution

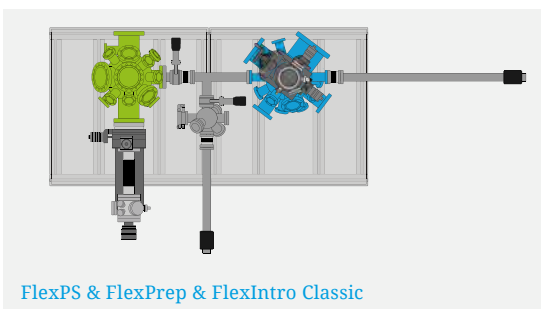

FlexPS & FlexPrep & FlexIntro Classic

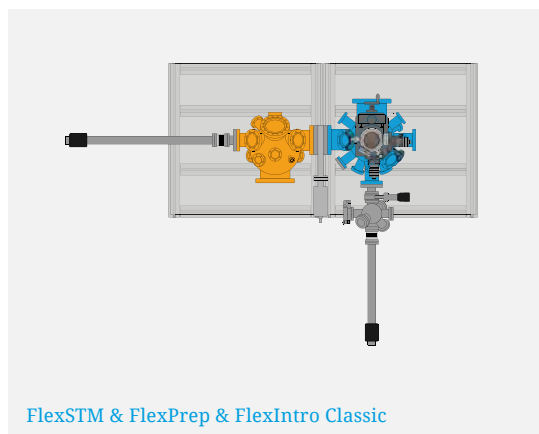

FlexSTM & FlexPrep & FlexIntro Classic

SPECS Surface Nano Analysis GmbH
Voltastrasse 5
13355 Berlin / Germany
www.specs-group.com

T +49 30 46 78 24-0
F +49 30 46 42 083
E info@specs-group.com

Version 02.03

SPECSTM